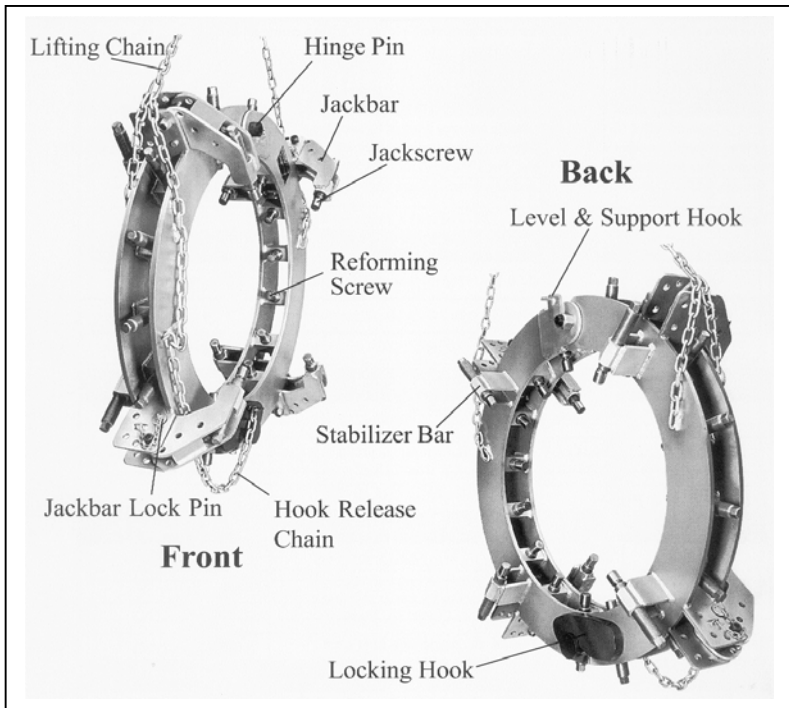




# 711 SERIES RIM CLAMP

## Parts and Operating Manual



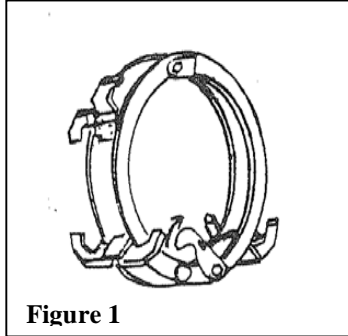
Part #	Pipe Size Range (in./mm.)	Reforms Pipe to Schedule	Aligns Pipe to Schedule	Shipping Weight (lbs./kg.)
D711-0406	4-6/102-152	80	120	40/18
D711-0608	6-8/152-203	80	120	50/23
D711-0810	8-10/203-254	80	120	70/32
D711-1012	10-12/254-305	80	120	90/41
D711-1214	12-14/305-356	80	120	120/54
D711-1416	14-16/356-508	80	120	190/86
D711-1618	16-18/406-457	80	120	240/108
D711-1420	14-20/356-508	80	120	280/126
D711-1824	18-24/457-610	80	120	350/158
D711-2026	20-26/508-660	80	120	260/162
D711-2228	22-28/559-711	80	120	380/171
D711-2632	26-32/660-813	80	120	400/180
D711-3036	30-36/762-914	80	120	420/189
D711-3440	34-40/864-1016	80	120	450/203
D711-3844	38-44/965-1118	80	120	490/221
D711-4248	42-48/1067-1219	80	120	510/230
D711-4450	44-50/1118-1270	80	120	610/275
D711-4652	46-52/1168-1321	80	120	610/275
D711-5056	50-56/1270-1422	80	120	680/306
D711-5460	54-60/1372-1524	80	120	750/338
D711-5864	58-64/1473-1626	80	120	820/369
D711-6268	62-68/1575-1727	80	120	880/396
D711-6672	66-72/1676-1829	80	120	950/428

Mathey Dearman D711 Series Rim Clamp are the “**Clamps with Muscle**” for the tough reforming Jobs. Jackscrews apply pressure on specific high points to precisely reform and align the pipes or shells.

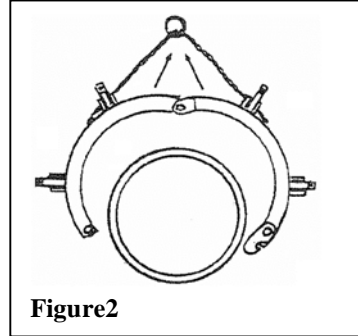
**FOR ALL YOUR PIPE CUTTING AND CLAMPING  
EQUIPMENT REQUIREMENTS, SEE YOUR NEAREST  
MATHEY DEARMAN DISTRIBUTOR OR CONTACT US  
.....1-800-725-7311**

Mailing Address: Po Box 472110 Tulsa, Ok 74147-2110 USA  
Shipping Address: 4344 S. Maybelle Ave. Tulsa, OK 74107 USA  
Phone: (918) 447-1288 Fax: (918) 447-0188 Email: [sales@mathey.com](mailto:sales@mathey.com)

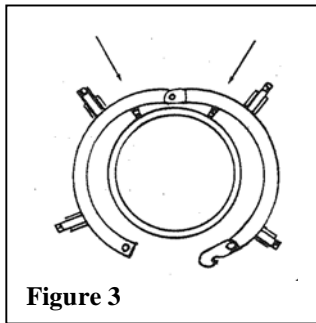
## Instructions for the use of the Dearman Rim Clamp



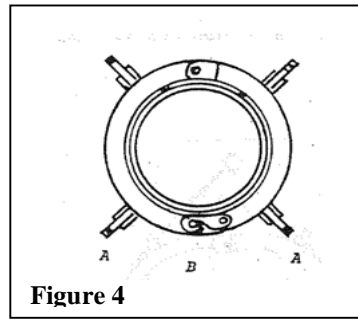
1. **Unlatch** the Locking Hook by **pulling upward** on the Hook Release Chain



2. To **open** the clamp, **lift it** by the lifting chain, if applicable. The clamp can now be **placed over the pipe**.

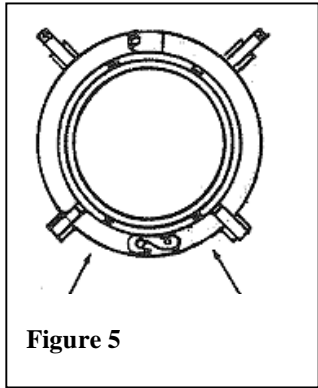


3. **Back off** all Reforming Screws, with the exception of the two near the top (as shown) **prior to lowering** clamp onto pipe. This procedure will allow the locking hook on bottom of the clamp to latch shut.



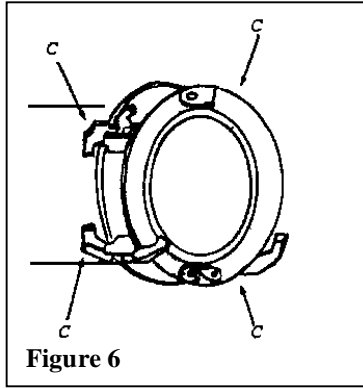
4. The clamp **should be positioned** on the pipe so the Jackbars (A), will extend beyond the end of the pipe 1 – 2 inches, **allowing** the Jackscrews on the Jackbars to grip the incoming piece of pipe. **Close** clamp until the Locking Hook (B) has latched.

**Note: Make sure Locking Hook latch is closed.**



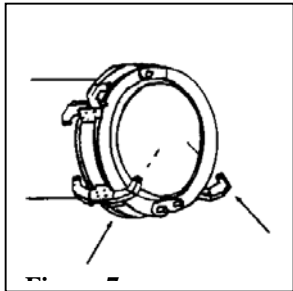
**Figure 5**

5. **Tighten** the two (2) Reforming Screws at each bottom quarter to approximately **center the clamp** on the pipe. **Adjust** the two top Reforming Screws (see step 3), to help the center clamp. The clamp does not have to be exactly centered on the pipe.

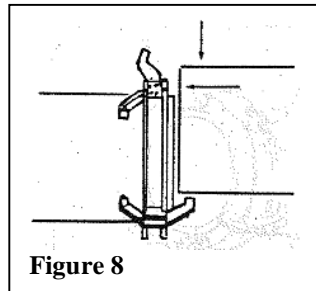


**Figure 6**

6. **Snug the rear** Stabilizing Bars Jackscrews (C) against the pipe. The Stabilizing Jackbar stops the clamp from twisting on the pipe. **Adjust** these screws to square up the clamp on the pipe.

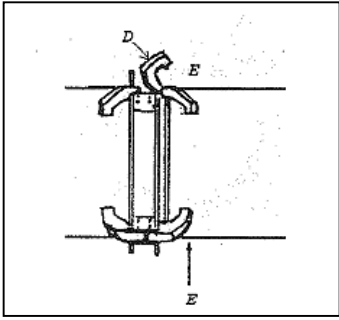


7. **Adjust** the two (2) Jackscrews on bottom Jackbars to line up with the O.D. of the pipe that is to be aligned.



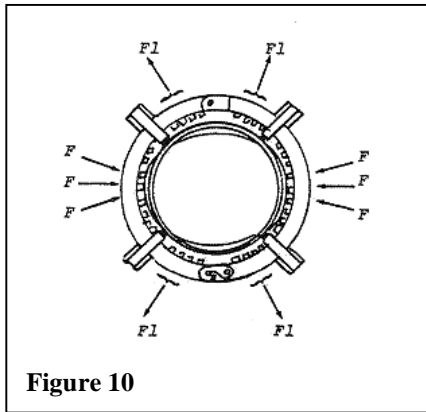
**Figure 8**

8. **Pin back** the upper two moveable jackbars with the Jackbar Locking Pins to stop them from hindering the lowering of the second pipe into position in the clamp.



9. At the point the pipe is resting on lower Jackscrews of the Jackbars **remove** the Jackbar Locking Pins from the upper Jackbars (D) and **lower** them into position. Use Jackscrews (E), of Jackbars to **move or shift** the pipe into alignment with the piece of pipe that the clamp is around.

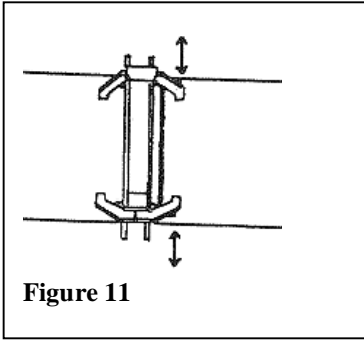
**Note: Do not try to reshape the incoming pipe.**



**Figure 10**

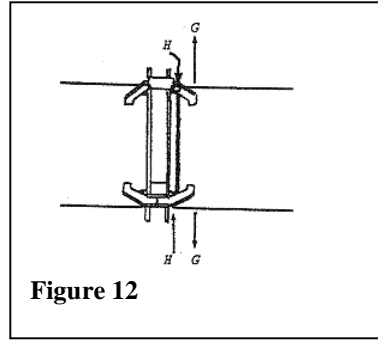
10. When the two (2) pieces of pipe are **aligned as close as possible**, **determine** the Reforming Screws that can be used to re-shape the pipe to the mating pipe. **Adjust** the Reforming screws as needed to re-shape the pipe to match the piece of pipe that is to be aligned. **Use** the Reforming Screws only where the high spots exist (F). It will be necessary to **reduce the pressure** on some of the Reforming Screws (F1) as you **tighten others**. It may be necessary to **repeat this procedure several times** before completing the fit-up. A small amount of pressure is all that is need, if the Reforming Screws are used to apply pressure only on the high spots.

**Note: It is a common mistake to use all the Reforming Screws at the same time.**



**Figure 11**

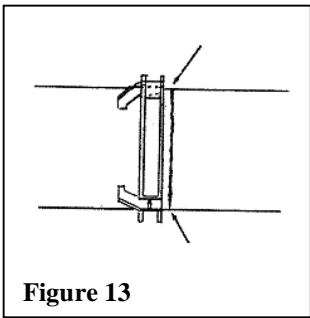
11. At the point that the two (2) inside or outside diameters are in near alignment, *use* the Jackscrews on the Jackbars to *move* the incoming pipe into perfect alignment.



**Figure 12**

12. *Loosen* the Jackscrews (G) enough to hold the pipe loosely in place, after adequate tack welding. *Remove* the Jackbar Locking Pins (H) from the upper Jackbars allowing the jackbar to be *rotated out of the way*. Reinsert the pin.

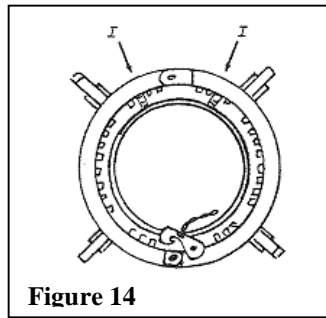
*Note: The Jackbar can be left in place in position during the entire welding process if required.*



**Figure 13**

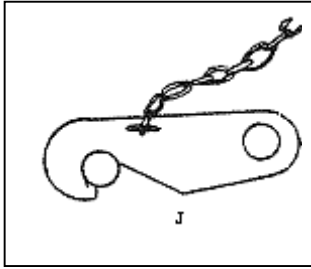
13. The entire weld area is now exposed for completing the weld and grinding process without having to release the reforming portion of the clamp.

*Note: Following this procedure will eliminate any chance of a weld fracture due to the clamp relieving the stress on a partially completed weld, and will result in a much higher quality of weld.*



**Figure 14**

14. When you have sufficient amount of weld, and are ready to take the clamp off, *loosen all* Reforming Screws and Jackscrew. You may *leave* the two top Reforming Screws (I), one on each side of the hinging point, extended down 1/2" more than the others so the clamp *will be resting* on the screws when you *loosen* the rest of them.



15. The locking hook (J) *can be unlatched* when a sufficient amount of pressure has been released from the Reforming Screws. *Pull upward* on the Hook Release Chain while lifting the clamp.

### **Maintenance**

1. All Reforming Screws and Jackscrews should be inspected after each clamping operation for splatter and other foreign debris. Any slag, splatter and other foreign debris should be removed prior to the next clamping operation.
2. All Reforming Screws and Jackscrews should be checked for damaged threads. If the threads are damaged, the threads should be filed smooth so that the Jackscrew will smoothly move in and out of the Jackscrew Nut.
3. Anti-seize compound should be applied to all Reforming Screws and Jackscrews daily.

### **Special Applications**

The Rim Clamp should be allowed to cool, when the welding inner pass temperature exceeds 375°F (190°C), before attempting to remove the clamp from the pipe.

## Warranty

If any merchandise sold hereunder (except merchandise manufactured by other persons or firms) by Mathey Dearman, Inc. (the "Company") is not in accordance with specifications shown on the order within customarily accepted tolerances, or is defective on account of workmanship or material, and if such merchandise is returned at the customer's expense and risk, to the Company's manufacturing facility (or at the Company's option, is returned to a repair facility authorized by the Company), within ninety (90) days after the Company's date of shipment thereof, the Company will, at its option, replace or repair the merchandise. This agreement, however, is upon the conditions: (A) that the customer promptly notifies the Company in writing of any claim under this agreement, setting forth in detail any such claimed defect. (B) That the Company be afforded a reasonable opportunity to examine the merchandise and to investigate the claimed defect at the Company's manufacturing facility or at an authorized repair facility, the Company shall not be, in any event, liable for damages beyond the price paid by the customer for such defective merchandise; specifically but without limitation, the Company may fulfill its obligations under this Agreement by tendering such purchase price at any time. THE COMPANY SHALL NOT BE LIABLE FOR CONSEQUENTIAL, INCIDENTAL, PUNITIVE, OR EXEMPLARY DAMAGES. This agreement does not obligate the Company to bear any transportation charges in connection with the replacement or the repair of defective merchandise. As to any item manufactured by other persons or firms, the Company agrees to present a request for adjustment for repair to such manufacturer, and the customer agrees that the liability of the Company shall not exceed any adjustment with respect to which such manufacturer accepts responsibility. THE ABOVE AGREEMENT IS IN LIEU OF ALL WARRANTIES, EXPRESSED OR IMPLIED AND IT IS AGREED THAT THERE IS NO EXPRESSED OR IMPLIED WARRANTY BY THE COMPANY AS TO THE FITNESS, MERCHANTABILITY CAPACITY, OR EFFICIENCY OF ANY MERCHANDISE SOLD, AND THAT THERE ARE NO ORAL OR WRITTEN EXPRESSED OR IMPLIED WARRANTIES MADE IN CONNECTION WITH ANY SALE BY THE COMPANY. No modification or addition to this agreement, either before or after the contract of sale, shall be made except on written authority of the President or Vice President of the Company.

If you have any question concerning the Warranty,  
of the MSA Saddle Machine,  
contact the Mathey Dearman Sales Department at  
Toll Free: 800-725-7311 • 918-447-1288 •  
Fax: 918-447-0188 • sales@mathey.com fax