



Po Box 472110, Tulsa, OK 74147 USA
Toll Free: 800-725-7311
918-447-1288 office
918-447-0188 fax
www.mathey.com

5SA Saddle Machine Operation & Safety Manual



MATHEY DEARMAN INC.

Safety

Proper precautions should be taken when using the **Short Saddle Cutting and Beveling Machine** or any and all other heavy cutting and welding equipment. A little common sense goes a long way towards preventing accidents involving your Mathey Dearman Saddle Machine.

1. Make sure ring and pinion gears are free from obstacles, especially hands and feet, before engaging machine.
2. **Observe operation of machine** to make sure loose clothing, tools, belts, etc. do not become entangled on the gear teeth or torch arm.
3. Fire is hot. Keep all flammable material, including hands and feet, as far from the path of the cutting torch as possible.
4. Keep all motor parts and accessories away from water to avoid electrocution.

Maintenance

Your Mathey Dearman Pipe Cutting and Beveling Machine requires only minimal maintenance; however, these are precision machines. In order to achieve proper results, make sure your machine is handled with reasonable care and **is** kept clean and **properly** lubricated.

The ring gear, pinion gears, and drive chains should be kept clear of slag and other trapped abrasives, especially sand and dirt. The saddle, ring gear, and cap ring should be cleaned and the ring gear track surfaces should be coated with lubricant (Lubriplate 130-AA or equal) at intervals of 30 and 60 days, and before storing. The drive chains and sprockets should be cleaned regularly and coated with a film of a light lubricant (WD-40 or similar).

During transporting or when not in use, the machine should be stored in a protective container such as a Mathey Dearman Machine Storage Box or the original factory shipping crate.

Mathey Dearman 5SA Pipe Cutting & Beveling Machine

Installation of Spacers on the 5SA Machine Saddle

Install the correct Spacer Bolts (4 bolts) in the four holes in the 5SA Machine Saddle, with the Spacer end of the bolts on the bore (I.D.) side of the saddle.

The correct size Spacers for the pipe size to be cut or beveled must be used to align the machine firmly around the pipe. Spacer I.D. surfaces must be in solid contact with the O.D. pipe surface.

Caution: When back beveling, the cutting flame and “hot” zone of the pipe are directed toward the machine. It is very important that the Torch be positioned as far as possible to the opposite end of the Torch Arm to prevent the heat from damaging the machine Saddle and Ring Gear.

Warranty

If any merchandise sold hereunder (except merchandise manufactured by other persons or firms) by Mathey Dearman, Inc. (the “Company”) is not in accordance with specifications shown on the order within customarily accepted tolerances, or is defective on account of workmanship or material, and if such merchandise is returned at the customer’s expense and risk, to the Company’s manufacturing facility (or at the Company’s option, is returned to a repair facility authorized by the Company), within ninety (90) days after the Company’s date of shipment thereof, the Company will, at its option, replace or repair the merchandise. This agreement, however, is upon the conditions: (A) that the customer promptly notifies the Company in writing of any claim under this agreement, setting forth in detail any such claimed defect. (B) That the Company be afforded a reasonable opportunity to examine the merchandise and to investigate the claimed defect at the Company’s manufacturing facility or at an authorized repair facility, the Company shall not be, in any event, liable for damages beyond the price paid by the customer for such defective merchandise; specifically but without limitation, the Company may fulfill its obligations under this Agreement by tendering such purchase price at any time. **THE COMPANY SHALL NOT BE LIABLE FOR CONSEQUENTIAL, INCIDENTAL, PUNITIVE, OR EXEMPLARY DAMAGES.** This agreement does not obligate the Company to bear any transportation charges in connection with the replacement or the repair of defective merchandise. As to any item manufactured by other persons or firms, the Company agrees to present a request for adjustment for repair to such manufacturer, and the customer agrees that the liability of the Company shall not exceed any adjustment with respect to which such manufacturer accepts responsibility. **THE ABOVE AGREEMENT IS IN LIEU OF ALL WARRANTIES, EXPRESSED OR IMPLIED AND IT IS AGREED THAT THERE IS NO EXPRESSED OR IMPLIED WARRANTY BY THE COMPANY AS TO THE FITNESS, MERCHANTABILITY CAPACITY, OR EFFICIENCY OF ANY MERCHANDISE SOLD, AND THAT THERE ARE NO ORAL OR WRITTEN EXPRESSED OR IMPLIED WARRANTIES MADE IN CONNECTION WITH ANY SALE BY THE COMPANY.** No modification or addition to this agreement, either before or after the contract of sale, shall be made except on written authority of the President or Vice President of the Company.

Note: The use of Hex Head Cap Screws (11) of the proper length is very important, if the screws are too long they will contact Ring Gear and you will not be able to rotate the Ring Gear.

16. Move the Single and Double Bearing Bracket downward and outward until the chain is taunt with a soft face hammer. Adjust the Right and Left Single Bearing Bracket Assemblies so there is .007” – .010” play between the Ring Gear (3) and Pinion Gear (3) of the Single Bearing Bracket Assembly.

Note: When pressure is applied to the top of the chain, it should flex about 3/16”.

17. Rotate the Ring Gear (3) clockwise (as viewed from the front of the machine) until the gap in the ring gear is at the 12:00 position.
18. Rotate the Pinion Gears (3) of the Bearing Bracket Assemblies so that they are evenly spaced in the teeth of the Ring Gear.
19. **Tighten one** of the Socket Head Set Screws (6) in each Sprocket (2) of the single Bearing Bracket Assemblies.
20. Rotate the Ring Gear (3) one full revolution in the clockwise and counterclockwise direction checking the entry of the Ring Gear (3) into the Pinion gears (3).

Note: The entry of the Pinion Gears (3) into the Ring Gear (3) should be smooth and without hesitation. The Pinion Gears should not push or pull the Ring Gear as it enters or leaves the Pinion Gears.

21. Tighten the Hex Head Cap Screw (11) that holds the Single and Double Bearing Brackets to the Saddle Assembly.

Note: Care should be taken not to over torque the Hex Head Cap Screws (11) as there are only 3 – 4 threads of engagement in the Saddle Assembly

22. Place the Tie Rod Handle (7) on the backside of the Single and Double Bearing Bracket and insert the 2 Flat Head Screws (12) in the holes of the Tie Rod Handle, install the Hex Nuts (13) and tighten.
23. Recheck the entry of the Ring Gear (3) into the Pinion gear (3) to insure that smooth and without hesitation.
24. The Machine is now ready for operation.

A Note on Back Beveling

Switching Mathey Dearman machines to back beveling is quick and easy. **Place Torch as close to Saddle as possible without placing flame directly on or near saddle when back beveling.** Rotate the Torch Clamp Base and Torch 180 degrees in the Torch Arm and re-tighten with thumb screw and clamp. The Torch will then be positioned for back beveling.

Bore Size (inside diameter) of 5SA Machine Saddle	30-1/2”	(775 mm)
Subtract actual OD of pipe	28”	(711mm)
Difference	2-1/2”	(64mm)
Divide Difference by two (2)	2-1/2” ÷ 2	(32mm)
	= 1-1/4”	

The correct Spacer length (between outside diameter of pipe and inside diameter of saddle) is **1-1/4” (32mm)**.

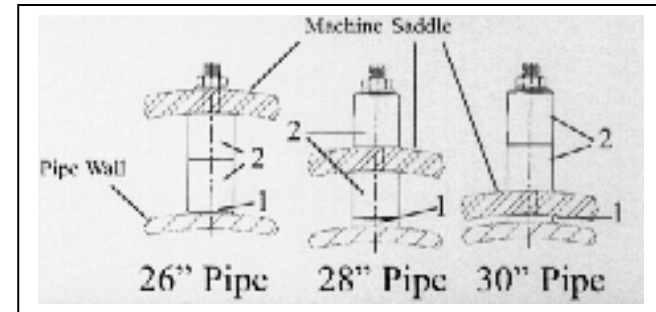

Figure 1: Spacer Configuration for 26”, 28” & 30” pipe. (660, 711, & 762mm respectively)

Item #	Part Description	Part #	Quantity
1	Spacer Bolt	03-0110-011	4
2	Spacer, 1” (25 mm)	04-0106-018	8
3	Spacer Bolt (24” Pipe)	03-0110-008	4

Installation of 5SA Machine on Pipe

Install the 5SA Machine Saddle squarely on the pipe, near the line to be cut or beveled (**measure as needed**).

Place the Boomer Assembly (Figure 2) around the pipe on the open side of the Machine. **Install** the hooked end of the Boomer hooks into the Boomer Eye on one side of the Machine Saddle. The S Hook on the other end of the Chain hooks into the Boomer Eye on the other side of the Machine Saddle and is secured with the Cotter Pin.

In order to get a stable installation, the Chain (3) must be adjusted on the S Hook so the Spring (2) is stretched approximately 3/4” to 1” (19-25mm) when the Boomer is closed.

When the Chain is properly adjusted, close the Boomer (1).

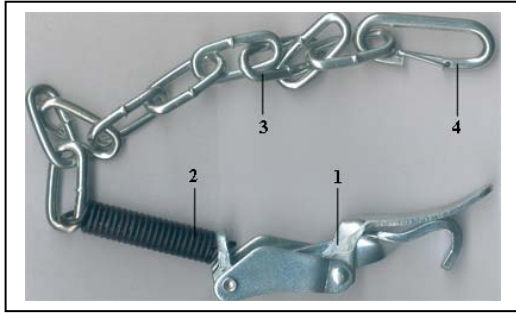

Figure 2: Boomer Assembly Part # 03.0105.017

Item #	Part Description	Part #	Quantity
1	Boomer	01-0258-001	1
2	Spring	01-0184-003	1
3	Chain	01-0577-006	1
4	Spring Snap	01-0258-003	1

**Figure 3:
Torch Arm**

Part Number: 03-0101-001

Torch Carrier Assembly

Part #: 03-0100-002

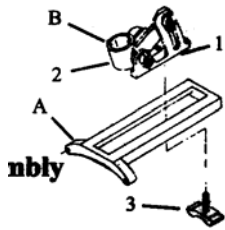

Item #	Part Description	Part #	Qty
A	Torch Arm	03-0101-001	1
	Double Torch Arm Kit	03-0105-025	Opt
B	Torch Carrier Assembly	03-0100-002	1
1	Torch Clamp Base	03-0100-003	1
2	Torch Clamp	03-0100-005	1
3	Clamp	03-0100-004	1
4	Screw Kit	03-0100-029	1

Installation of Torch Arm, Torch Carrier Assembly and Torch

Install Torch Arm (Fig. 3, Item A) by attaching it to the two threaded studs **located** in the face of the 5SA Machine Ring Gear at the 12 o'clock position. Secure **Torch Arm** with the wing nuts on the studs. Install and secure Torch Carrier **Assembly** (Fig. 3, Item B) **into the slot of the Torch Arm for an outward and for the Torch.**

The Torch Clamp Base (Fig. 3 Item 1) is marked 0, 60, and 90. **Use the '0'** position for square cuts (no bevel). **For** positions 60 and 90 make the appropriate bevel to produce a V groove of 60 and 90 degrees respectively when the two pipe ends are butted together.

Procedure for Timing the Ring Gear to the Pinion Gears & Installation of new Drive Chains

This process requires that you purchase 2 new Axles, part number **03-0103-008**. **Double drilling the Axles severely weakens them and will cause failure** after a very short period of time.

1. Remove both Spring Pins (11) from the Right and Left Single Bearing Bracket Sprockets (2).
2. Loosen the Socket Set Screw (6) in both the Right and Left Single Bearing Brackets.
3. Remove the Sprockets (2) from the Axles (4)
4. Separate the Axles (4) and Pinion Gears (3) from the Bearing Brackets.
5. Remove the Spring Pins (10) and press the Axles out of the Pinion Gears (3)
6. Press the New Axles (4) into the Pinion Gears (3) until they are flush with the end of the Pinion Gear.
7. Drill through the Pinion Gear (3) and Axle (4) with a 3/16" drill.
8. Insert the Spring Pin (10) into the drilled hole in the Pinion Gear (3)
Note: Make sure the Spring Pin (10) is all the way through the Axle (4) and into the other side of the Pinion Gear (3).
9. Insert the Axles back into the Bearings (5) in the Bearing Brackets, until the Pinion gears (3) **are** flush with the end of the bearing
10. Install the Sprocket (2) onto the Axle (4) until it contacts with the face of the bearing (6). Make sure that it rotates freely.
Note: Do not tighten the set screws or drill and install the Spring Pins at this time.
11. Remove the outer Hex Head Cap Screws (11) from the Right and Left Single Bearing Bracket Sprocket (2).
12. Loosen the inner Hex Head Cap Screws (11) from the Right and Left Single Bearing Bracket Sprocket so that bracket will rotate.
13. Rotate the Single Bearing Bracket Assemblies toward the center of the machine.
14. Place the Drive Chains on the Sprockets (2) of the Single Bearing Bracket Assemblies and the Double Sprocket (3) of the Double Bearing Bracket Assembly.
15. Move the Right and Left Single Bearing Brackets downward, install the outer Hex Head Cap Screws (11) in the Bearing Bracket Assemblies and tighten the Screw only snugly. Do not tighten them at this time.

Install Torch in Torch Clamp (Fig. 3, Item 2) and adjust to a stand off distance recommended by the Torch manufacturer.

Note: Before starting to cut or bevel, rotate Torch one full turn around the pipe to be sure Torch tip will clear all the way around the pipe.

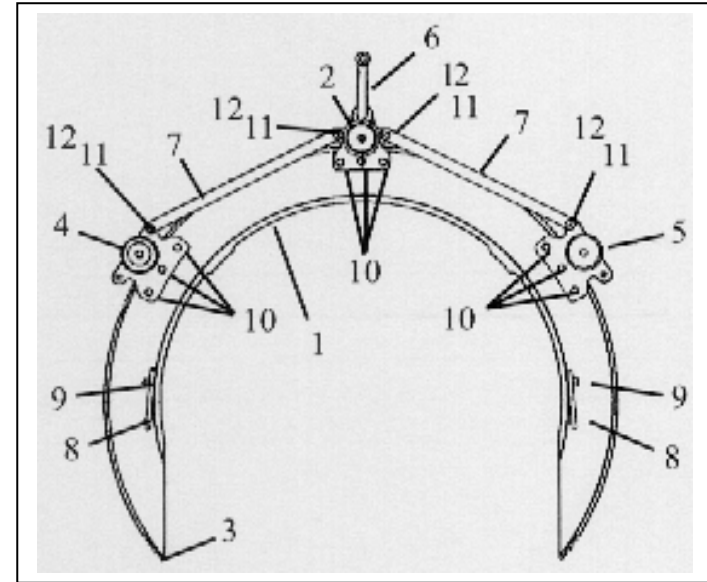

Figure 4: 5SA Machine – Manual Part # 03-0105-000

Item #	Part Description	Part #	Qty.
1	Saddle	03-0105-001	1
2	Cap Ring	03-0105-003	1
3	Ring Gear	03-0105-002	1
4	Single Bearing Bracket Assembly (left)	03-0105-005	1
5	Single Bearing Bracket Assembly (right)	03-0105-004	1
6	Double Bearing Bracket Assembly	03-0105-007	1
7	Handle Tie Rod	03-0105-016	2
8	Boomer Eye	03-0101-017	2
9	Cap Screw, hex head, 5/16", 18NC x 5/8"	10-56C0-058	11
10	Cap Screw, hex head, 3/8", 16NC x 7/8"	10-38C0-078	9
11	Cap Screw, hex head, 3/8", 16NC x 1-1/4"	10-38C0-114	4
12	Washer, flat, 3/8"	12-0038-F00	13
	Drive Chain	03-0105-015	2
	Washer, flat, 1/2" w/ Spacer Bolts	12-0012-F00	4
	Nut, Hex 1/2" w/ Spacer Bolts	1H-12C0-000	4
	Threaded Stud (Ring Gear)	01-0194-003	2
	Wing Nuts, 5/16"	1W-56C0-000	2
	Spring Pins, 3/16" x 1-1/4"	18-3160-114	2

TROUBLESHOOTING – MANUAL MACHINE

Symptom	Possible Cause(s)	Corrective Action
Machine is cutting out of square	Incorrect spacer bolts	Use only Mathey spacer bolts.
	Washer is installed between the saddle and the spacer bolt.	Install washer on the threaded portion of the spacer bolt protruding out of the saddle.
	Pipe is over or under size or out-of-round.	Use the PRO-Model Torch Arm to compensate for over or under size and out-of-round pipe.
	Customer is cutting tubing.	Contact Mathey Dearman Sales Department for special size Spacer Bolts for tubing.
	Customer is back beveling the pipe.	Use of the Double Torch Arm Attachment is strongly recommended. Save time and money by making both bevels simultaneously.
	All 4 spacer bolts are not in contact with pipe.	Reposition machine so that all 4 spacer bolts make contact with pipe and re-latch boomer.
	Torch, torch arm or torch carrier is loose.	Tighten wing nuts or thumbscrews.
	Hoses are binding.	Wrap the hose 1 full turn around the pipe. Rotate the ring gear of the machine so the hoses unwrap during the cutting process.
	Machine has been dropped.	Send the machine to a certified repair station for resizing cap ring, ring gear and saddle.
	Torch is at end of torch arm.	Move the torch closer to the ring gear.
Machine hesitates or stops as the pinion gear enters the ring gear.	The Pinion Gears too shallow in the large ring gear.	Readjust the bearing brackets so the pinion gear is at the correct depth per the repair instructions.
	The timing of the pinion gears to the ring gear is off.	Readjust the timing per the repair instructions.
	The drive chain is stretched.	Readjust the bearing brackets to eliminate the slack in the chain per the repair instructions. If the slack can not be eliminated replace the drive chain.

TROUBLESHOOTING – MOTORIZED MACHINE

Symptom	Possible Cause(s)	Corrective Action
Gear motor does not rotate	No electrical power at outlet.	Select another electrical outlet.
	Wire broken between plug and motor.	Replace electrical cord.
	DC Cord had electrical short.	Replace motor control box (part # 03.0203.009)
	Fuse blown	Replace fuse with 2 amp fuse (part # 01.0427.008)
Motor lags at low speed	Motor operating below power curve.	Increase size of cutting tip so that motor speed can be increased.
Machine vibrates	Motor mounting screws are loose.	Tighten motor mounting screws.
	Motor and Pinion shafts are out of alignment.	Realign motor to coupling.

Figure 6: Double Bearing Bracket Assembly

Part # 03.0105.010

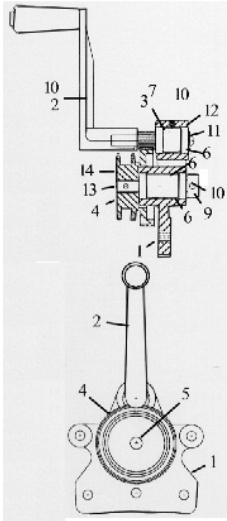

Item #	Part Description	Part #	Qty
1	Bracket	03-0105-011	1
2	Crank Handle Assembly	03-0103-012	1
3	Crank Pinion	03-0105-012	1
4	Crank Gear and Double Sprocket	03-0105-014	1
5	Axle	03-0105-013	1
6	Bearings	01-0196-012	1
7	Spacer	04-0106-011	1
8	Spacer	04-0106-013	1
9	Set Collar, 1/2"	01-0185-005	1
10	Set Screw, 1/4" , 20NC x 1/2"	19-14C0-012	4
11	Screw, round head 1/4", 20NC x 1/2"	14-14C0-012	1
12	Washer, flat, 1/4"	12-0014-F00	1
13	Spring Pin, 3/16" x 1-1/4"	18-3160-114	1
14	Spiral Ring, 1/2"	01-0179-014	1

Figure 5: Single Bearing Bracket Assembly

Left Side Assy: Part# 03-0105-004

Right Side Assy: Part# 03-0105-005

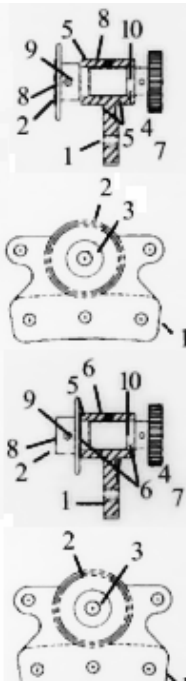

Item #	Part Description	Part #	Qty.
1	Bracket	03-0105-006	1
2	Sprocket	03-0105-008	1
3	Axle	03-0105-009	1
4	Pinion Gear	03-0105-007	1
5	Spacer	04-0106-013	1
6	Bearing	01-0196-002	2
7	Set Screw, 5/16", 18NC x 5/16	19-56C0-056	1
8	Set Screw, 1/4", 20NC x 1/4"	19-14C0-014	2
9	Spiral Ring, 1/2"	01-0179-014	1
10	Spring Pin, 3/16" x 1"	18-3160-100	1
11	Spring Pin, 3/16" x 1-1/4"	18-3160-114	1

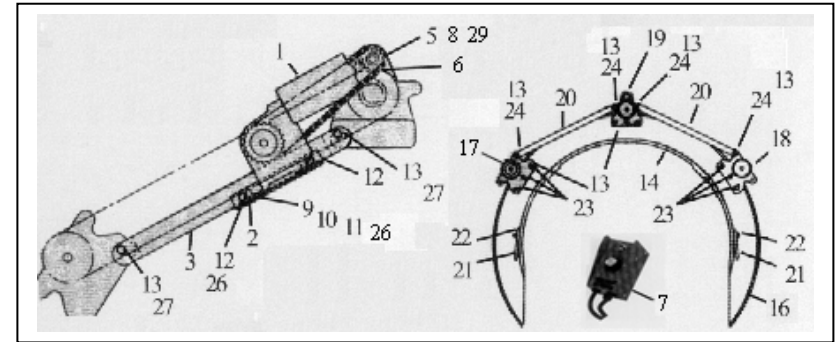

Figure 7: 5SA Machine – Motorized, Part #03-0105-M00

Item #	Part Description	Part #	Qty
1	Gearmotor	03-0201-053	1
2	Motor Mounting Bracket	03-0103-028	1
3	Bracket Mounting Bar	03-0105-024	1
4	Drive Sprocket	03-0101-008	1
5	Driven Sprocket	03-0103-026	1
6	Chain	03-0104-017	1
7	Motor Control Box	03-0203-009	1
8	Spacer	04-0106-051	1
9	Cap Screw, hex head, 1/4", 20NC x 5/8"	10-14C0-058	3
10	Nuts, hex, 1/4"	1H-14C0-000	3
11	Washer, flat, 1/4"	12-0014-F00	3
12	Cap Screw, hex head, 5/16", 18NC x 1/2"	10-56C0-012	2
13	Cap Screw, hex head, 3/8", 16NC x 1-1/4"	10-38C0-114	6
14	Saddle	03-0105-001	1
15	Cap Ring	03-0105-003	1
16	Ring Gear	03-0105-002	1
17	Single Bearing Bracket Assembly (left)	See pg. 6	1
18	Single Bearing Bracket Assembly (right)	See pg. 6	1
19	Double Bearing Bracket Assembly	See pg. 6	1
20	Handle Tie Rod	03-0105-016	2
21	Boomer Eye	03-0101-017	2
22	Cap Screw, hex head, 5/16", 18NC x 5/8"	10-56C0-058	11
23	Cap Screw, hex head, 3/8", 16NC x 7/8"	10-38C0-078	7
24	Washer, flat 1/4"	12-0038-F00	4
25	Washer, internal lock, 1/4"	12-0014-100	3
26	Washer, internal lock, 3/8"	12-0038-100	2
27	Washer, lock, 3/8"	12-0038-L00	2
28	Set Screw, 5/16", 18NC x 5/16"	19-5600-056	1
29	Washer, flat, 3/8"	12-0038-F00	1